

# Photon-photon scattering and axion-like particle generation

Baifei Shen  
Shanghai Normal University  
SIOM, CAS

# Outline

1. Background
2. High field Photon-photon scattering
3. High field axion-like particle generation

# Outline

1. Background

2. High field Photon-photon scattering

3. High field axion-like particle generation

# 超强超短激光的发展历程与科学新领域的开拓

超强超短激光：

峰值功率 > 1TW ( $10^{12}W$ )

脉冲宽度 < 100 fs ( $10^{-15}s$ )

超强超短激光  
最大光强已达  
 $2 \times 10^{22} W/cm^2$

宇宙中  $\gamma$ -爆对应的光强  $10^{20} W/cm^2$  \*

超强超短激光是人类已知的最亮光源，可以提供前所未有的全新实验手段与极端物理条件。

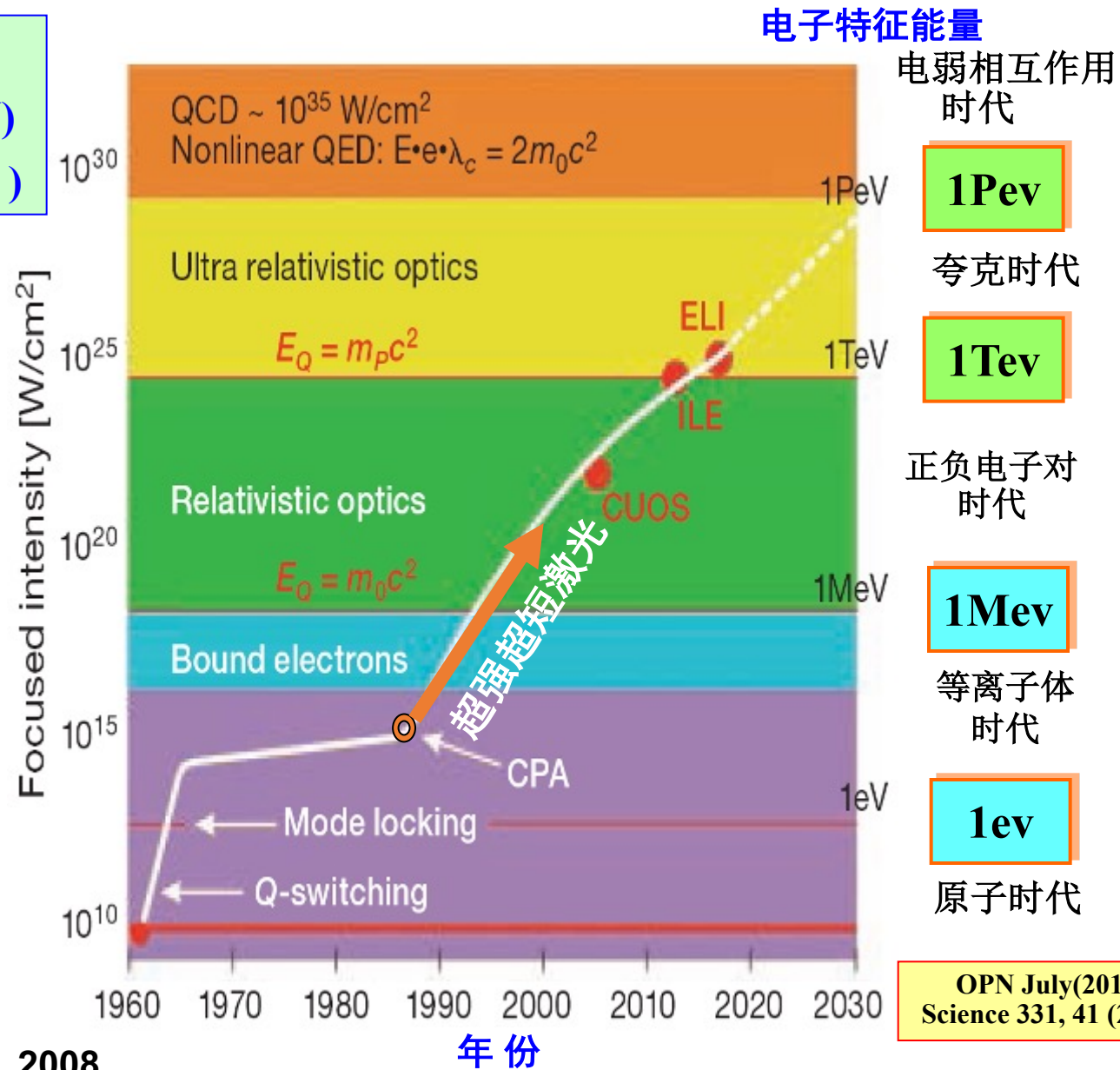

\* NewScientist April 9, 2008

# Optical laser parameters

- Normalized laser amplitude

$$a_0 = \frac{eA_0}{m_e c^2} = \frac{eE_0}{m_e \omega_L c}.$$

When  $a_0 = 1$ , an electron quivers relativistically in laser field.

- The corresponding laser intensity is

$$I_0 \lambda_L^2 = \delta \left( 1.37 \times 10^{18} \frac{\text{W}}{\text{cm}^2} \mu\text{m}^2 \right) a_0^2,$$

- Laser intensity is different in different reference frame, while the normalized laser amplitude  $a_0$  is a Lorentz invariant quantity.
- At present, the normalized laser amplitude  $a_0$  reaches a  $\sim 100$ .

# Optical laser parameters

- The normalized laser amplitude  $a_0$  can be written as

$$a_0 = \frac{eE}{mc\omega_L} = \frac{eE \cdot \lambda_C}{\hbar\omega_L}, \quad \lambda_C = \frac{\hbar}{mc}.$$

- It describes the photon number which an electron can absorb within a Compton wavelength.
- Therefore, from the QED point of view, the high field ( $a_0 > 1$ ) is better expressed as nonlinear.

# Optical laser parameters

- The important parameter for the QED effects is the Schwinge field, describing the absorbed energy by an electron with a Compton wavelength equals the rest energy of an electron.

$$E_s = \frac{m^2 c^3}{e \hbar} = \frac{m c^2}{e \lambda_C}.$$

- At this field, pairs can be produced in vacuum.
- At present, while the normalized laser  $\mathbf{a_0}$  can be easily  $> \mathbf{1}$ , the laser field is still much smaller than the Schwinge field. Therefore, we discuss **the nonlinear QED physics ( $\mathbf{a_0} > \mathbf{1}$ ) in the weak field region(much smaller than the Schwinge field).**

# Why we need XFEL for QED physics?

- Since the optical laser field is still weak compared to the Schwinge field, we need another beam, such as electron beam or gamma beam to boost the QED effects. Here we consider to use XFEL.
- Compared to electron beams, the XFEL is cleaner without any matters of mass and charge.
- Compared to gamma beams, the XFEL can be measured precisely.



# 决定高能电子（光子）和强场相互作用QED效应的参数

$$\chi = \frac{1}{E_S mc} |F_{\mu\nu} p^\nu| = \frac{c}{E_S e \hbar} a |kp| = \frac{a}{m^2 c^2} |kp|$$

$$\chi = \frac{\gamma}{E_S} |\mathbf{E}_\perp + (\boldsymbol{\beta} \times \mathbf{B})|$$

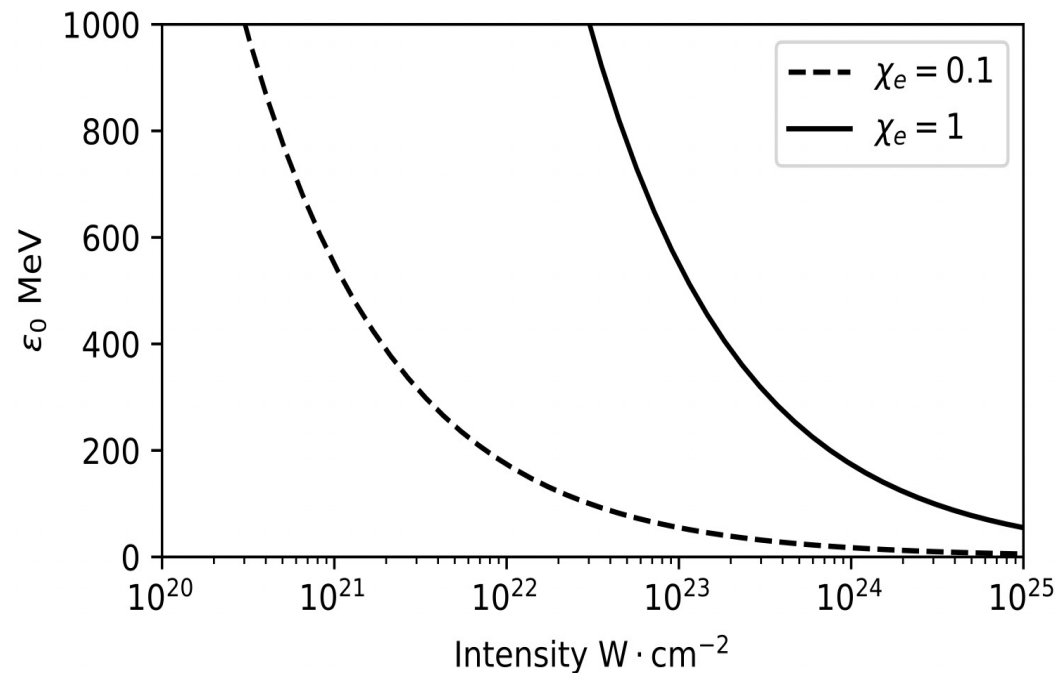

$$\eta = \frac{e \hbar^2}{2m^3 c^4} |F_{\mu\nu} k^\nu| = \frac{\hbar}{2E_S mc} |F_{\mu\nu} k^\nu| = \frac{\hbar \omega}{2mc^2 E_S} \left| \mathbf{E}_\perp + \left( \frac{\mathbf{k}}{k} \right) \times \mathbf{B} \right|$$

# Short wavelength laser may provide low cost new generation laser facilities of intensity approaching the Schwinger limit.

1. XFEL with CPA technique may provide attosecond 10 keV laser of focal size less than 10 nm.
2. 10 or 100 PW laser may produce 1EW laser of 1 J and 1 as.
3. Laser-produced ultra-intense gamma radiation may drive a gamma-ray laser.
4. Schwinger limit is not the ultimate limit for laser intensity, since plane wave does not produce pairs in vacuum.

# Station of Extreme Light (SEL) at XFEL

The marriage of two most intense light sources :

1TW XFEL at 0.1nm + 100PW optical laser at 900nm

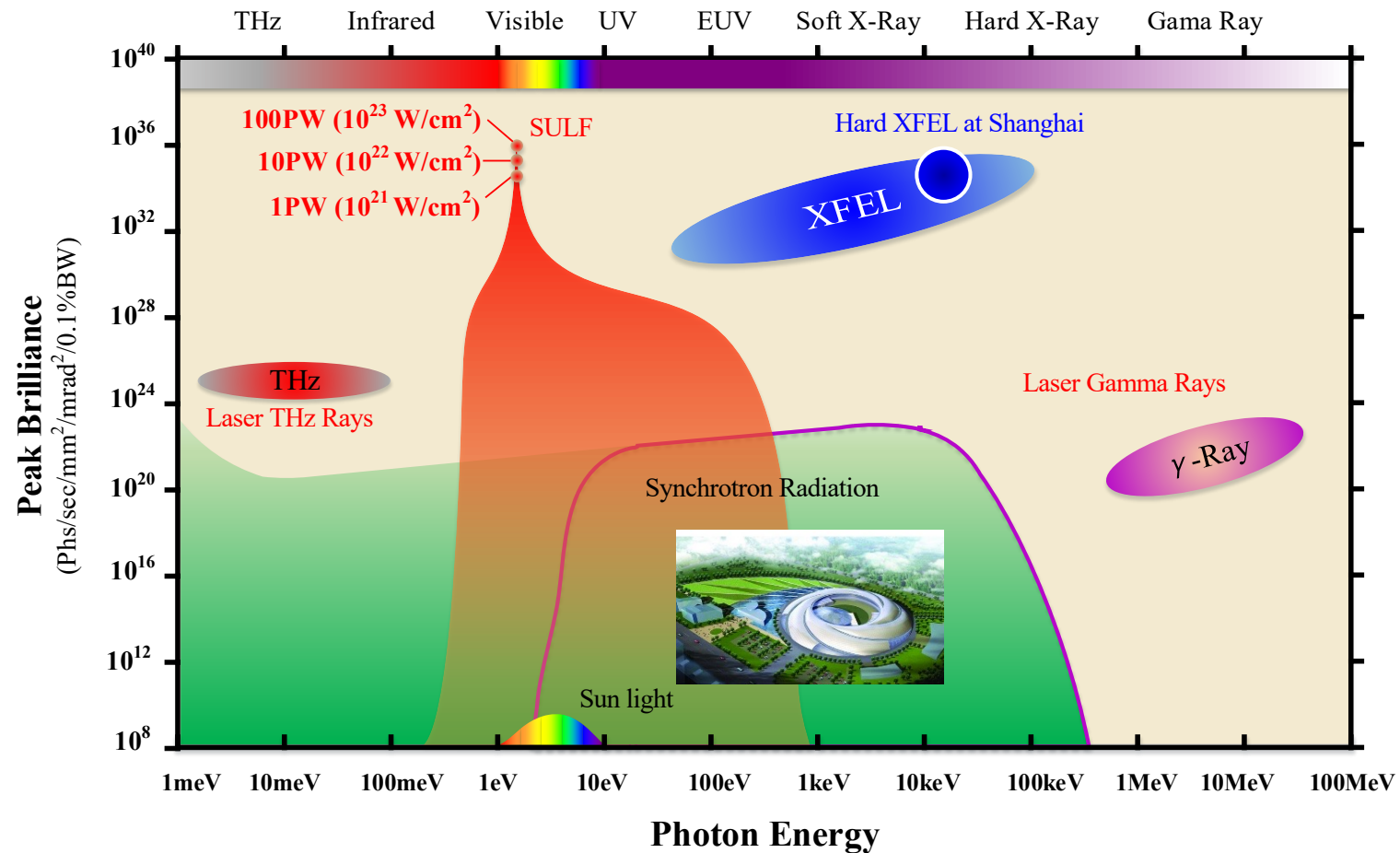

The building of Shanghai High repetition XFEL and Extreme light facility (SHINE) was started on 27 April, 2018.







# Interaction chamber

- 1000x1000 mm<sup>2</sup> 100PW laser pulse (1500J/15fs) coming from top is reflected to off-axis parabola near the chamber wall and then focused to XFEL in the middle of the chamber.

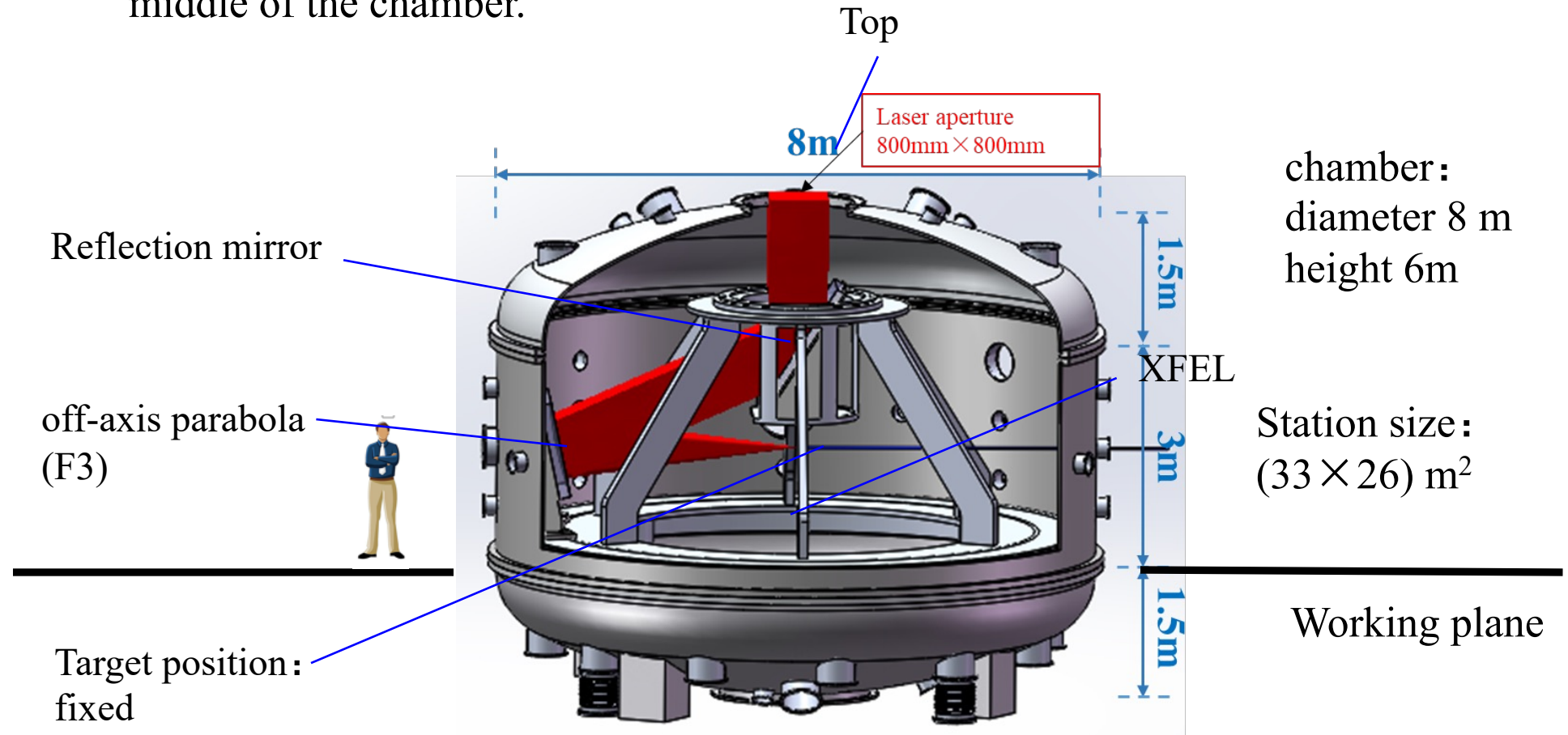

The interaction chamber has been installed.



# Outline

1. Background

2. High field Photon-photon scattering

3. High field axion-like particle generation



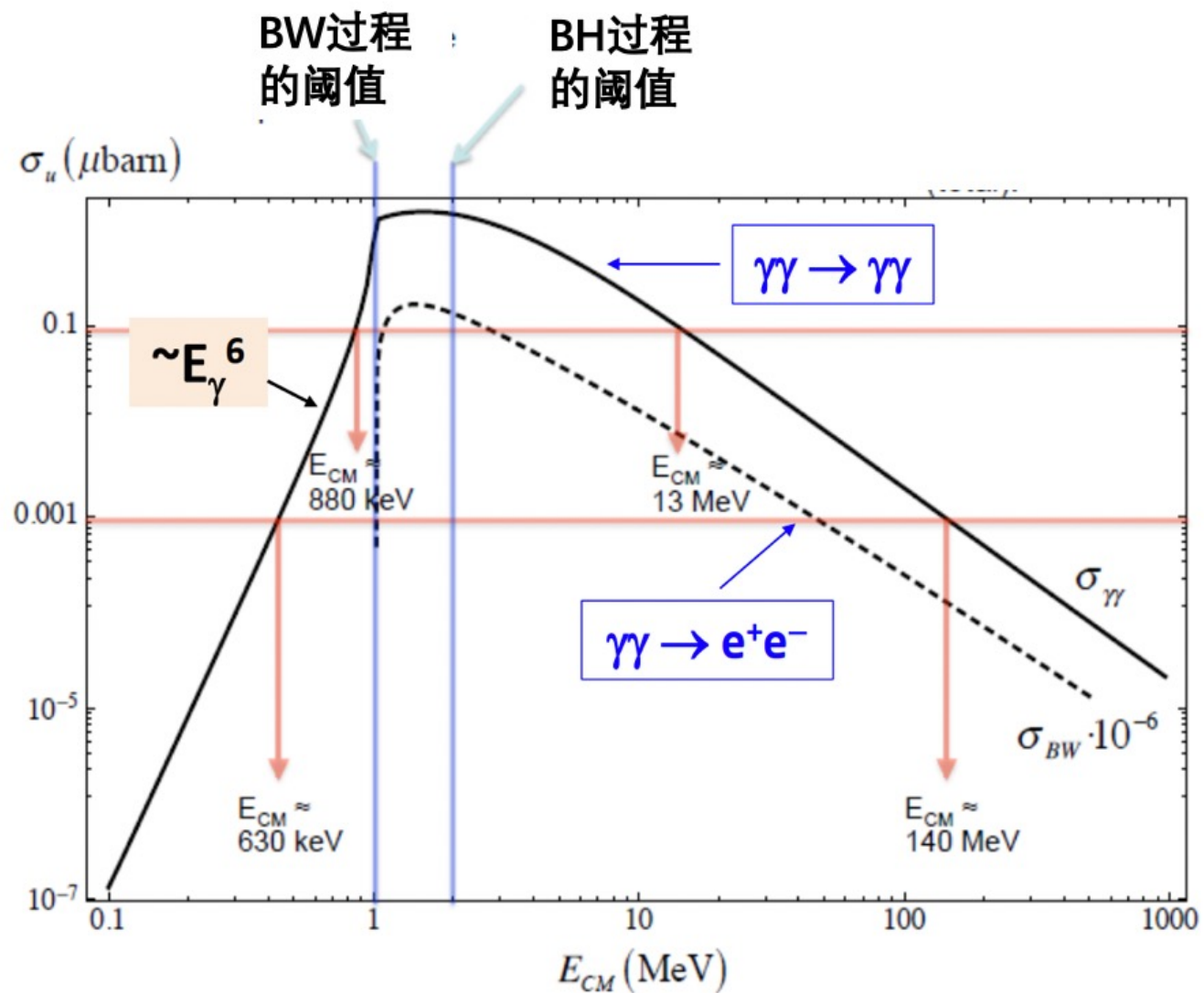

(单光子) 光光总散射截面随质心光子能量的变化

# High field Photon-photon scattering

## Theoretical methods :

Since the optical laser field is weak compared to the Schwinge field, the Lagrangian density is

$$\mathcal{L}_{EH} = \frac{\xi}{128\pi} \left[ 4(F_{\alpha\beta}F^{\alpha\beta})^2 + 7(\tilde{F}_{\alpha\beta}F^{\alpha\beta})^2 \right],$$

Here, the coupling coefficient  $\xi = \alpha/(45\pi E_s^2)$ ,

$$F_{\alpha\beta}F^{\alpha\beta} = -2(|E|^2 - |B|^2),$$

$$\tilde{F}_{\alpha\beta}F^{\alpha\beta} = -4E \cdot B.$$

# High field Photon-photon scattering

Theoretical methods :

With the Lagrangian density, we have

$$\mathbf{P} = \frac{\partial \mathcal{L}_{EH}}{\partial \mathbf{E}} = \frac{\xi}{4\pi} [2(|\mathbf{E}|^2 - |\mathbf{B}|^2)\mathbf{E} + 7(\mathbf{E} \cdot \mathbf{B})\mathbf{B}],$$

$$\mathbf{M} = \frac{\partial \mathcal{L}_{EH}}{\partial \mathbf{B}} = \frac{\xi}{4\pi} [7(\mathbf{E} \cdot \mathbf{B})\mathbf{E} - 2(|\mathbf{E}|^2 - |\mathbf{B}|^2)\mathbf{B}].$$

Photon-photon scattering can change the polarization, energy and transverse momentum of the photons.

# Detecting vacuum birefringence with XFEL + 100 PW laser

In 1930' s, W. Heisenberg et al. predicted vacuum birefringence, the QED effect in vacuum. But it has never been observed in laboratory.



In 1940-50' s, Schwinger et al. established the systematic theory on QED and defined the Schwinger critical field.



In 1960, Maiman invented laser. the Schwinger critical field correspond to the laser intensity  $10^{29} \text{W/cm}^2$ . CPA technology helps the quick increase of laser intensity. But, with single ultra intense laser alone, it is still very difficult to study vacuum birefringence.

XFEL provides an excellent solution for us to detect high field vacuum birefringence in laboratory.

# Detecting vacuum birefringence with XFEL + 100 PW laser

The refractive factors for the XFEL beam along the laser electric field and magnetic field is

$$n_1 = 1 + c_2 \left[ \mathbf{E}^2 + 2\mathbf{E} \cdot (\hat{\mathbf{k}} \times \mathbf{B}) + (\hat{\mathbf{k}} \times \mathbf{B})^2 \right]$$

$$n_2 = 1 + c_1 \left[ \mathbf{E}^2 + 2\mathbf{E} \cdot (\hat{\mathbf{k}} \times \mathbf{B}) + (\hat{\mathbf{k}} \times \mathbf{B})^2 \right]$$

One efficient way is to collide the two beams to maximize the difference of the refractive factors.

$$\Delta\phi = 2\pi(n_1 - n_2) \frac{d}{\lambda_X} = \frac{4\alpha}{15} \frac{d}{\lambda_X} \frac{I_L}{I_S}$$

Taking into account the pulse profile in space and time domain, the modified ellipticity of the XFEL beam is

Laser intensity

$$\varepsilon = \left| \frac{i\Delta\phi}{2} \right|^2 = \frac{1}{4} \left( \frac{4\alpha}{15} \frac{\pi z_R}{\lambda_X} \frac{I_0}{I_S} \right)^2 G^2(z_R, \tau_R)$$

Wavelength of XFEL

# The physical design for the experiment of vacuum birefringence has been published .

IOP Publishing

Plasma Physics and Controlled Fusion

Plasma Phys. Control. Fusion **60** (2018) 044002 (11pp)

<https://doi.org/10.1088/1361-6587/aaa7fb>

## Exploring vacuum birefringence based on a 100 PW laser and an x-ray free electron laser beam

Baifei Shen<sup>1,2,3,4</sup> , Zhigang Bu<sup>1</sup>, Jiancai Xu<sup>1</sup>, Tongjun Xu<sup>1</sup>, Liangliang Ji<sup>1,2</sup>, Ruxin Li<sup>1,2</sup> and Zhizhan Xu<sup>1,2</sup>

<sup>1</sup> State Key Laboratory of High Field Laser Physics, Shanghai Institute of Optics and Fine Mechanics, Chinese Academy of Sciences, Shanghai 201800, People's Republic of China

<sup>2</sup> School of Physical Science and Technology, ShanghaiTech University, Shanghai 201210, People's Republic of China

<sup>3</sup> Shanghai Normal University, Shanghai 200234, People's Republic of China

E-mail: [bfshen@mail.shenc.ac.cn](mailto:bfshen@mail.shenc.ac.cn)

(2018)

# Detecting vacuum birefringence with XFEL + 100 PW laser

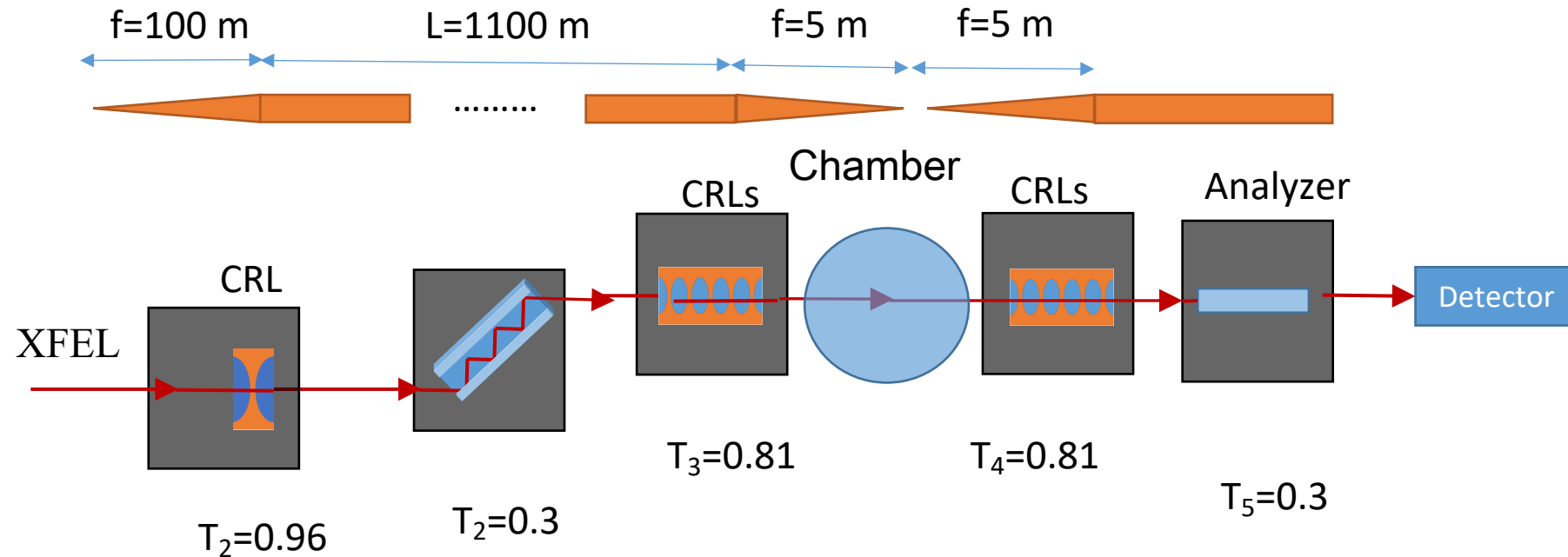

Propagation efficiency:  $T=T_1*T_2*T_3*T_4*T_5=0.055$

XFEL Photon number for detection per shot is  
 $10^{12} \times 1.74 \times 10^{-10} \times 0.055 = 9.6$

# Detecting vacuum birefringence with XFEL + 100 PW laser

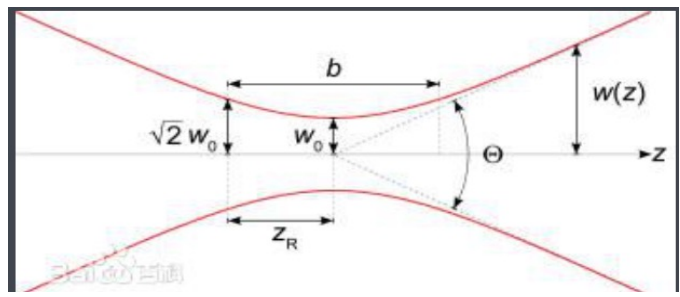
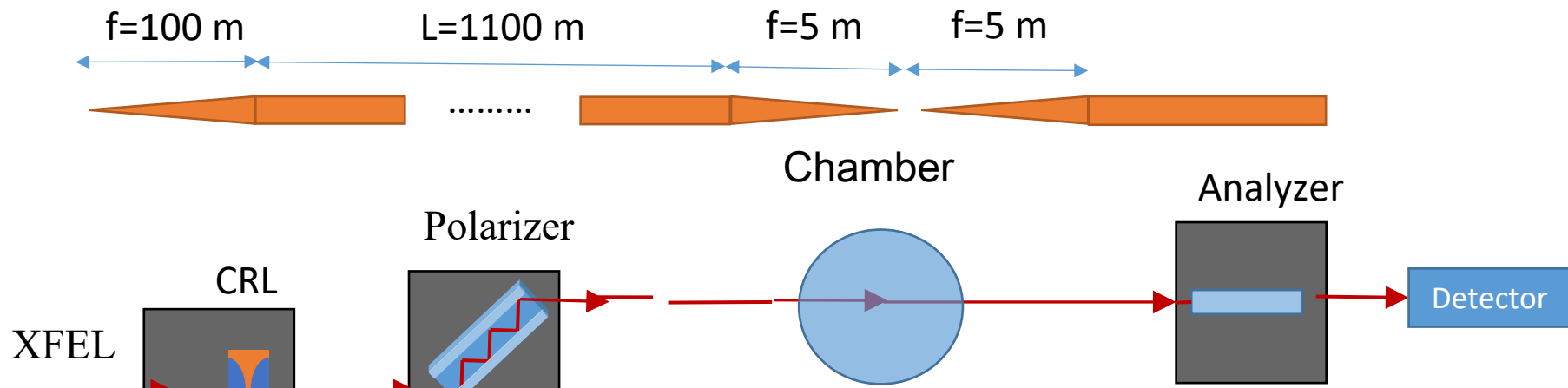

$$z_R = \frac{\pi w_0^2}{\lambda}$$

$$w(z) = w_0 \sqrt{1 + \left(\frac{z}{z_R}\right)^2} \approx \frac{\omega_0 z}{z_R} = \frac{\lambda}{\pi \omega_0} z = \frac{0.1 \text{ nm}}{3.14 \times 2.5 \mu\text{m}} 5 \text{ m} = 60 \mu\text{m}$$

For focal size 5μm

Damage threshold ?



# XFEL beamline layout for vacuum birefringence experiment

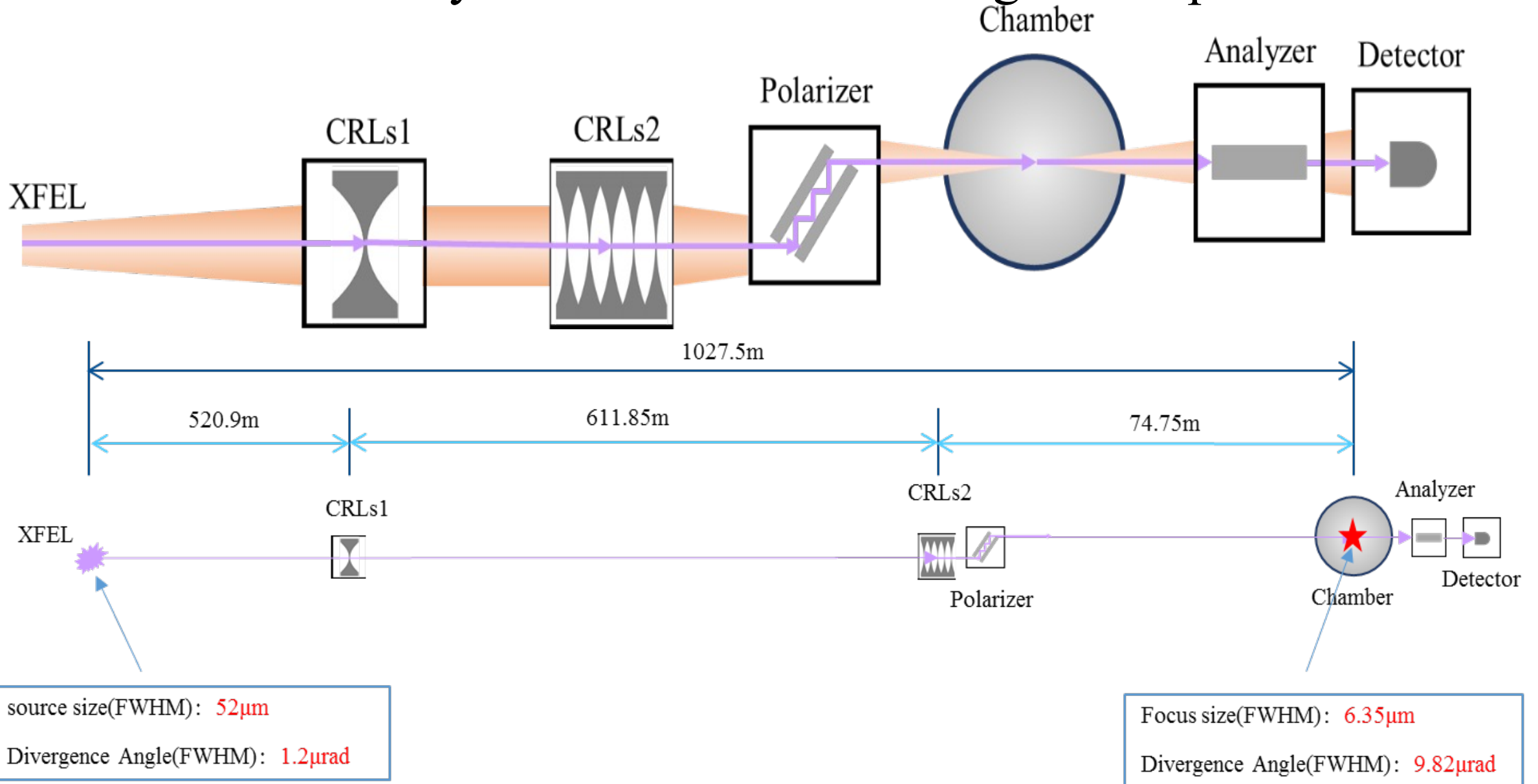

The cleaning method of vacuum is studied to improve the vacuum degree.

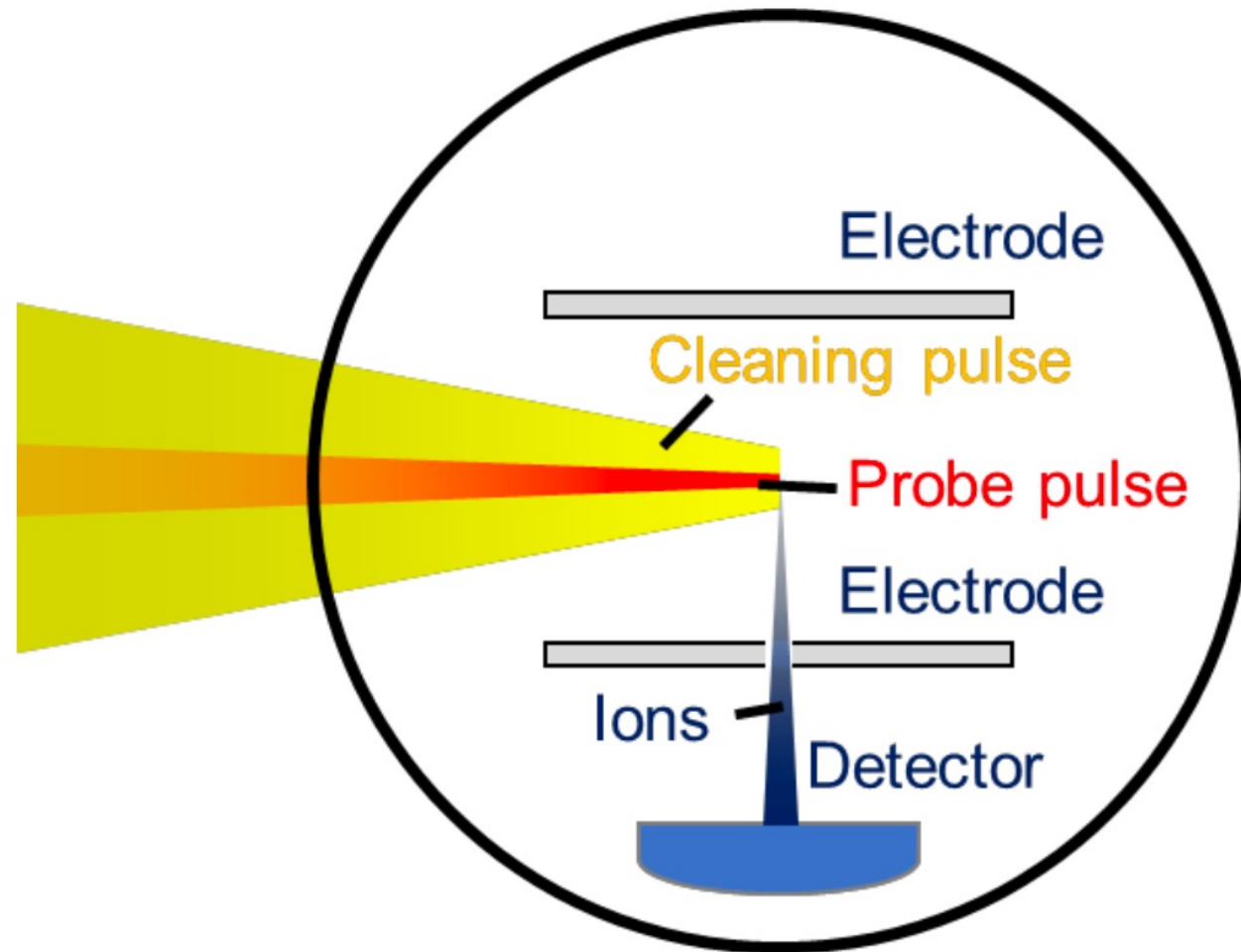

# Enhancement of vacuum birefringence with pump laser of flying focus

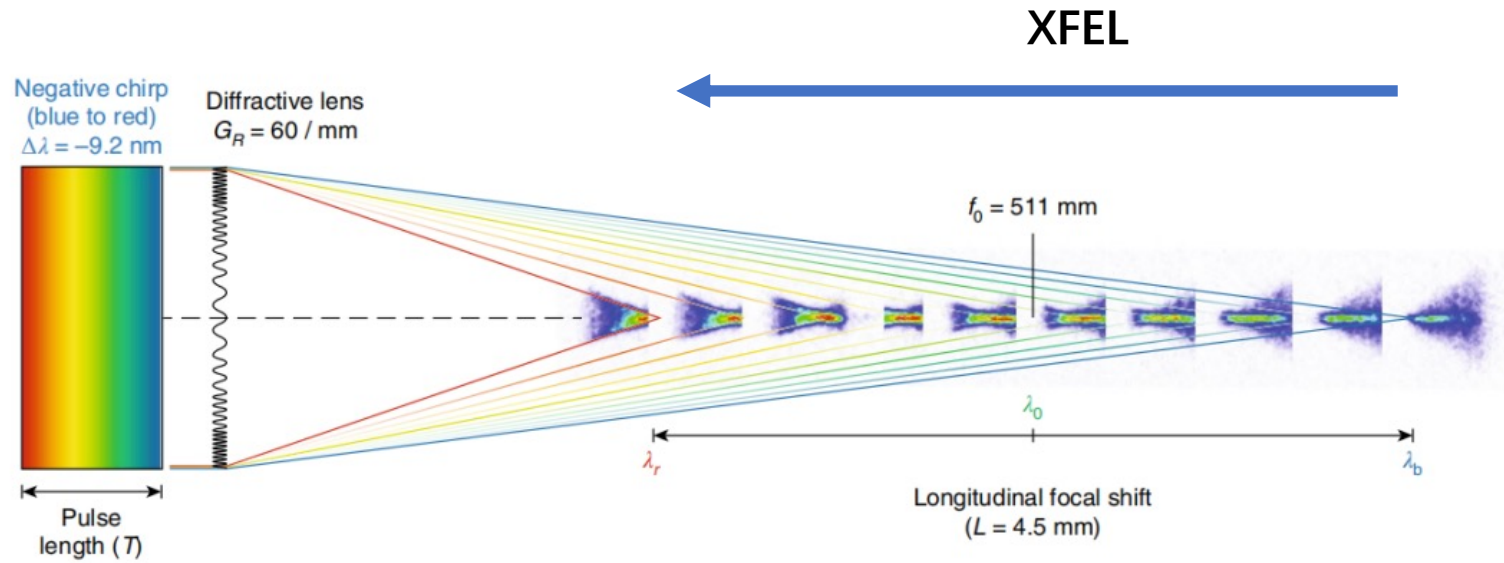

The velocity of the focal spot

$$v = \left(1 + \frac{d\tau}{d\lambda} \frac{d\lambda}{dz}\right)^{-1}$$

The lights of different frequencies are focused to the different positions.

# Enhancement of vacuum birefringence with pump laser of flying focus

- The velocity of the focal spot is  $-c$ .
- The probe light move together with the focal spot, so the interaction area is increased.

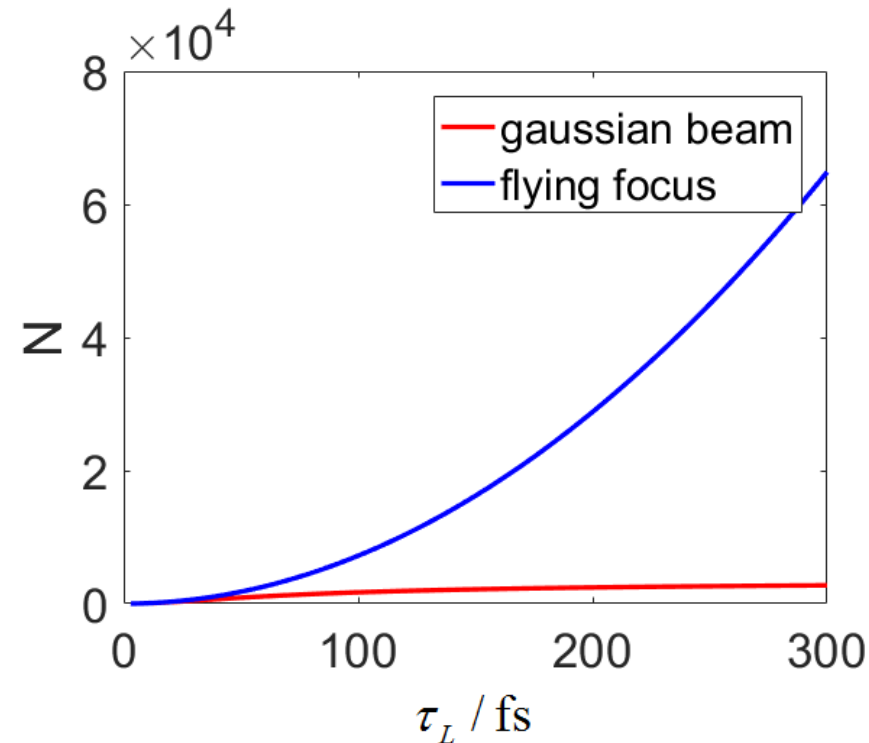

# Angular momentum may be used to increase the signal to noise ratio

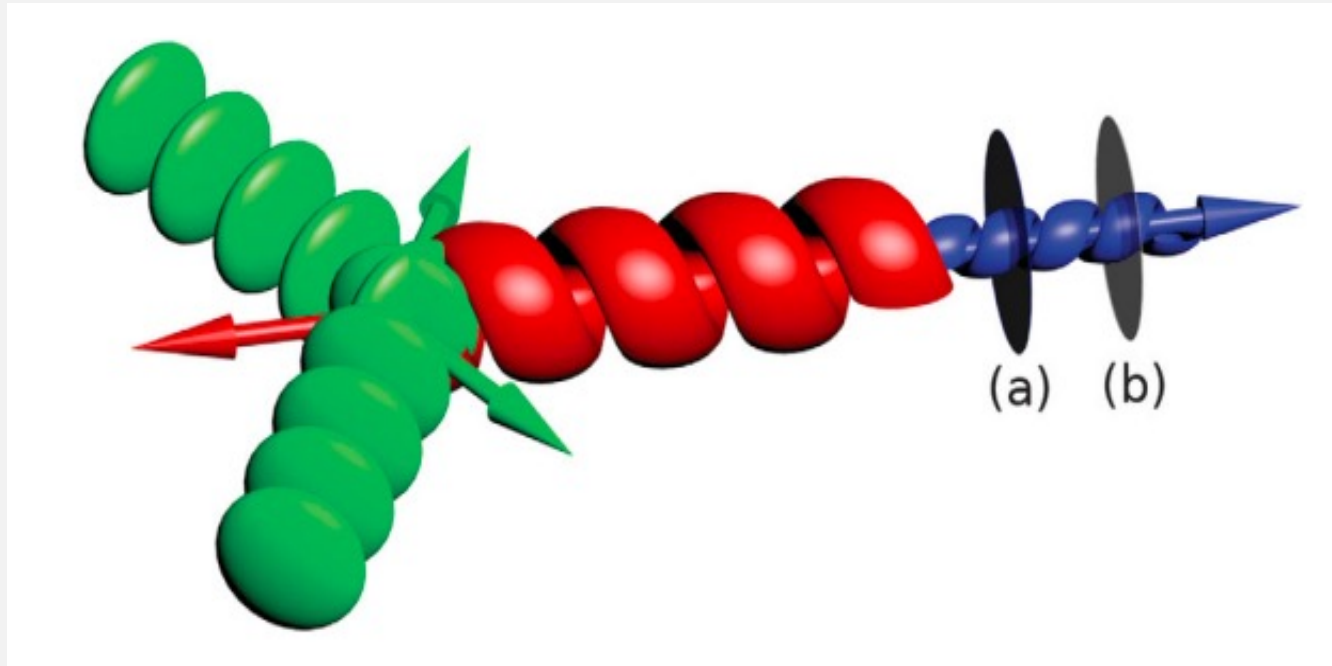

Input laser

$$\mathbf{k}_1 = k\mathbf{e}_z + \sqrt{3}k\mathbf{e}_x,$$

$$\mathbf{k}_2 = k\mathbf{e}_z - \sqrt{3}k\mathbf{e}_x,$$

$$\mathbf{k}_3 = -k\mathbf{e}_z,$$

$$l_3 = 1,$$

Scattering  
light

$$\mathbf{k}_4 = 3k\mathbf{e}_z,$$

$$l_4 = -1,$$

# Four wave mixing in vacuum

1. For the case of using XFEL and optical laser, one XFEL photon absorbs two optical photons, emitting a new signal photons.

$$L = \frac{1}{8\pi}(E^2 - B^2) + \frac{\xi}{8\pi}[(E^2 - B^2) + (\mathbf{E} \cdot \mathbf{B})]^2,$$

The photon energy is changed: one can measure the change of  
1eV@10keV

2. For planar waves propagating in the same direction, the process of four wave mixing does not happen.

## Photon–photon scattering in a plasma channel

Baifei Shen

*Ruhr-Universität Bochum, Institut für Theoretische Physik I, D-44780 Bochum, Germany  
and Shanghai Institute of Optics and Fine Mechanics, P.O. Box 800-211, Shanghai 201800, China*

M. Y. Yu

*Ruhr-Universität Bochum, Institut für Theoretische Physik I, D-44780 Bochum, Germany*

$$L = \frac{1}{8\pi}(E^2 - B^2) + \frac{\xi}{8\pi}[(E^2 - B^2) + (\mathbf{E} \cdot \mathbf{B})]^2,$$

As an example, for  $k_1=0$ ,  $\hbar\omega_L=1$  eV,  $\hbar\omega_2=1000$  eV, and  $\alpha_0=100$  (corresponding to a laser intensity of  $10^{22}$  W/cm<sup>2</sup>), we obtain  $E_{30}/E_{20} \sim 4 \times 10^{-10}$ . Thus, for a signal wave of intensity  $10^{17}$  W/cm<sup>2</sup>, the detected wave would have an intensity of  $1.6 \times 10^{-2}$  W/cm<sup>2</sup>. Such an intensity, as well as the relevant characteristics such as the polarization and the spectra, should be easily detectable if the much stronger channel and signal fields (both are known) are filtered out. In order to avoid severe loss in the strength of the generated wave, the filtering should be sufficiently abrupt.

## Four wave mixing

**$10^{22}$ W/cm<sup>2</sup> Optical laser  
+  $10^{17}$ W/cm<sup>2</sup>, 1 KeV XFEL**

$$\frac{E_{30}}{E_{20}} = \alpha \frac{\hbar^2(\omega_L - k_1 c)\omega_2}{240\pi m_e^2 c^4} \alpha_0^2 J_0^2, \quad (14)$$

# Wave mixing with three pulses

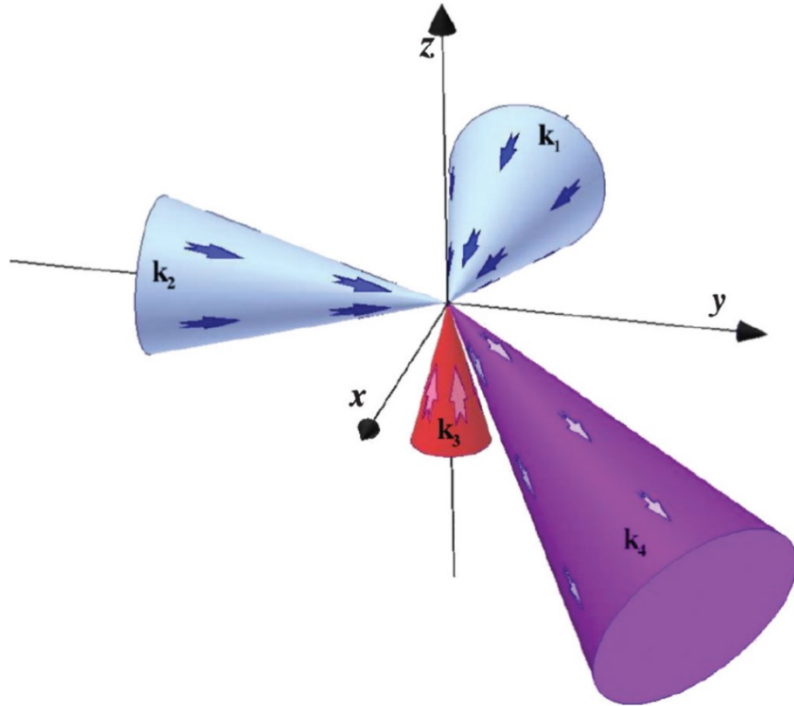

k1, k2: colliding lasers

k3 probe x-ray

k4: signal

*Laser powers*

Signal photon

$$N_{\gamma} \approx 0.25 \frac{P_1[\text{PW}]P_2[\text{PW}]P_3[\text{PW}]}{(\lambda_4[\mu\text{m}])^3}.$$

*Wave length of X-ray*

Phys. Rev. Lett. 96, 083602 (2006).

Phys. Plasmas14, 064503 (2007).



We propose to use colliding XFEL and optical laser to detect the four wave mixing signal

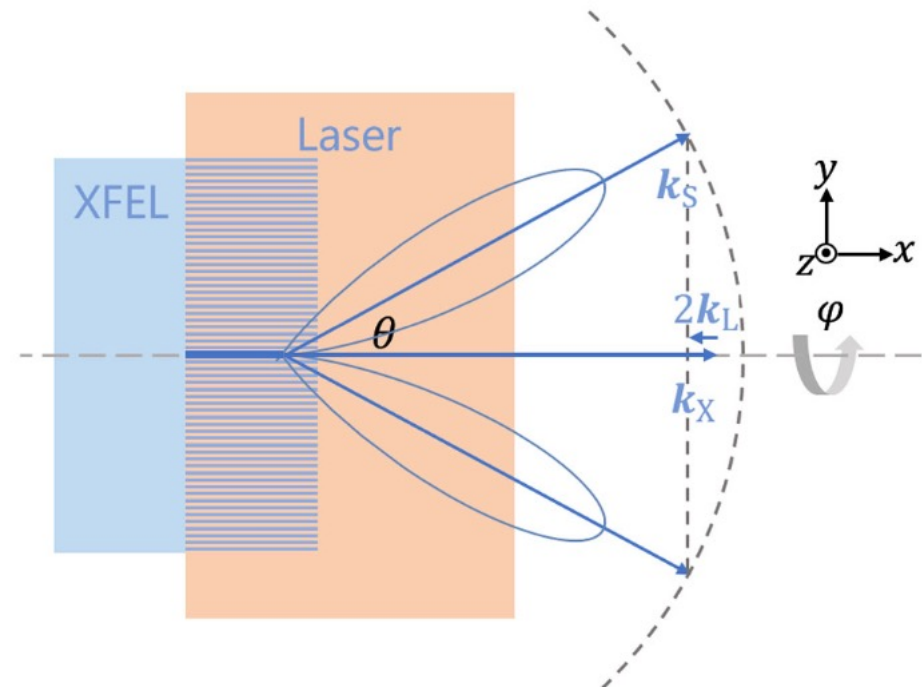
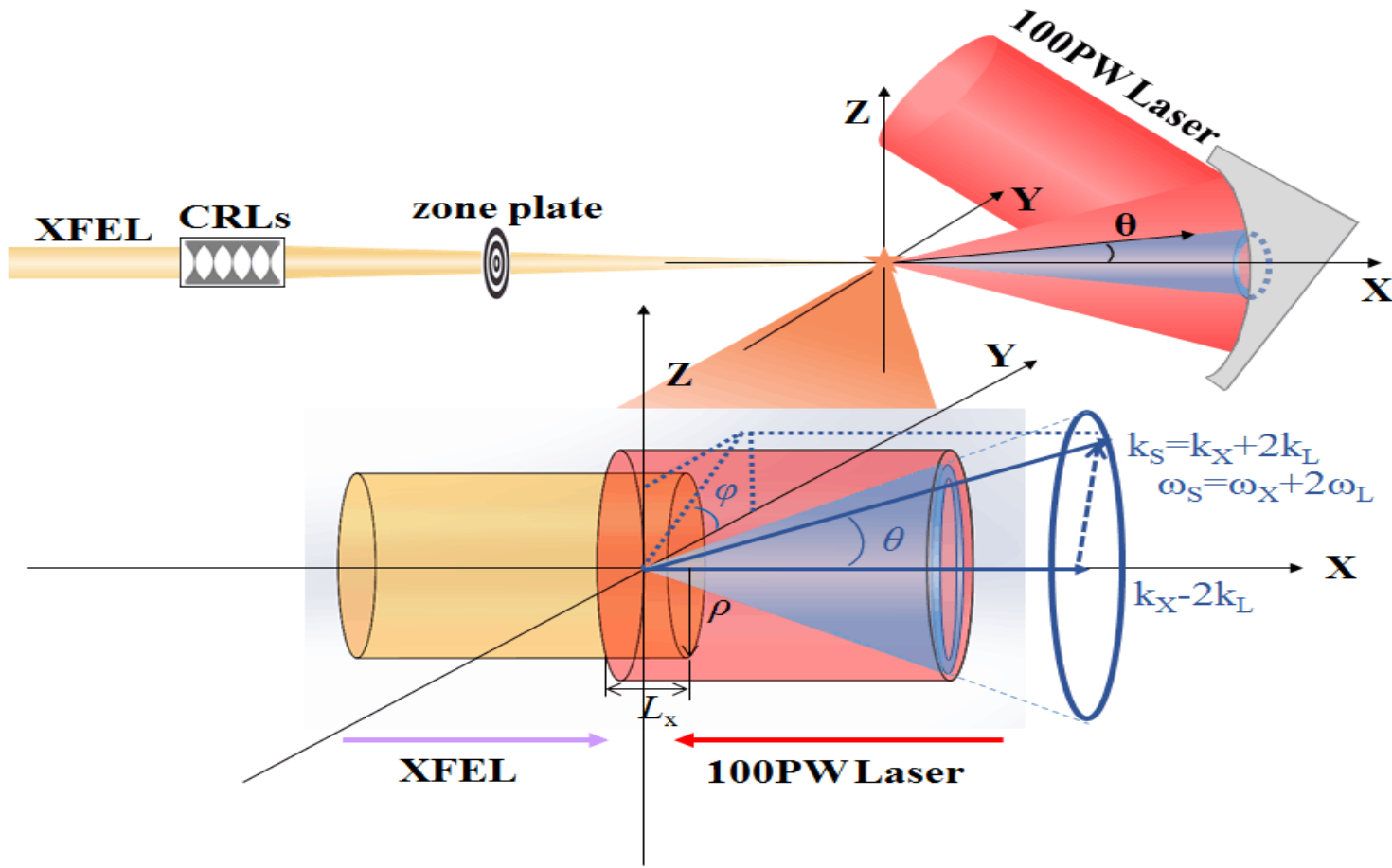

PHYSICAL REVIEW D 100, 013004 (2019)

Energy and momentum conservation ?

The signal depends on interaction length (Sinc function) and transverse size (Bessel function)

$$A_S = -\frac{1}{2\pi} \mathbf{e}_y \cdot \omega_X^2 A_{S0} \frac{e^{i(\omega_S t - k_S |\mathbf{x}| + \psi)}}{|\mathbf{x}|} \frac{V_{\text{Scatter}}}{k_S \rho \sin \theta} \cdot \text{sinc} \left\{ \frac{1}{2} (k_S \cos \theta - k_{Sx}) L_x \right\} \cdot J_1(k_S \rho \sin \theta).$$

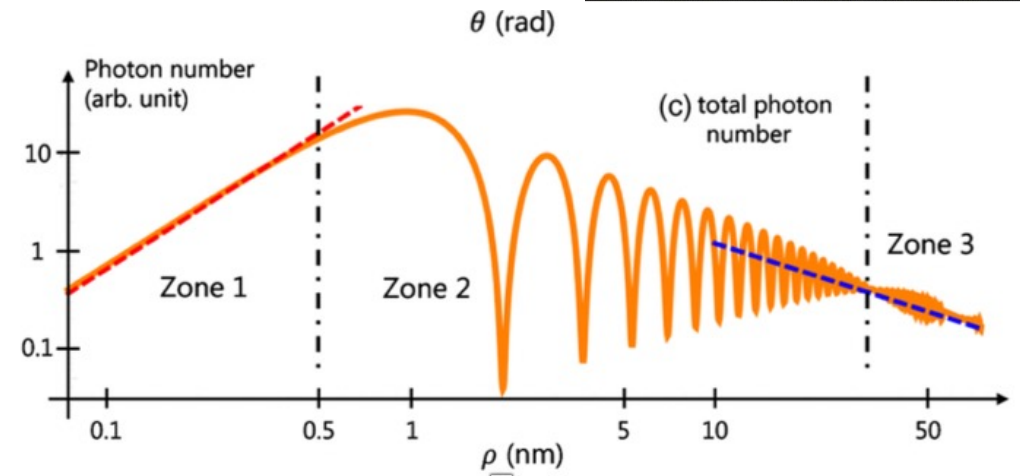
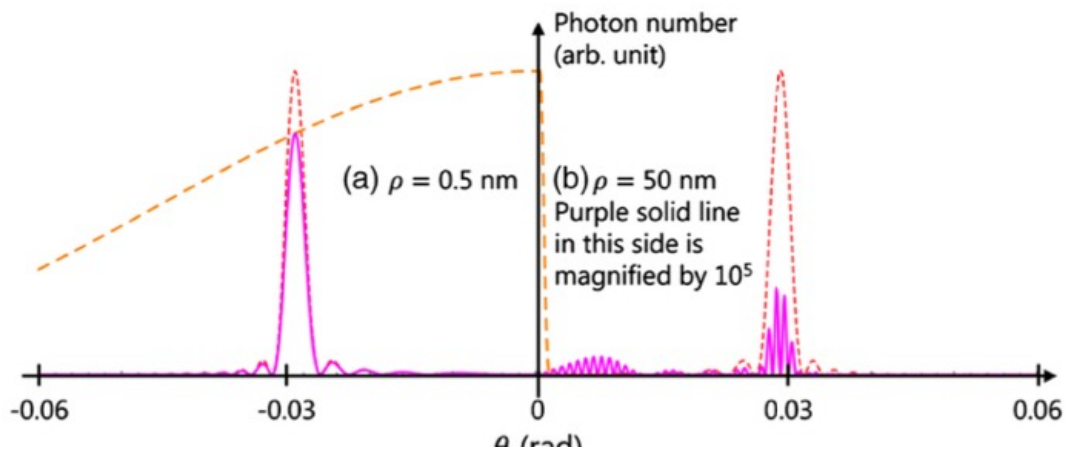
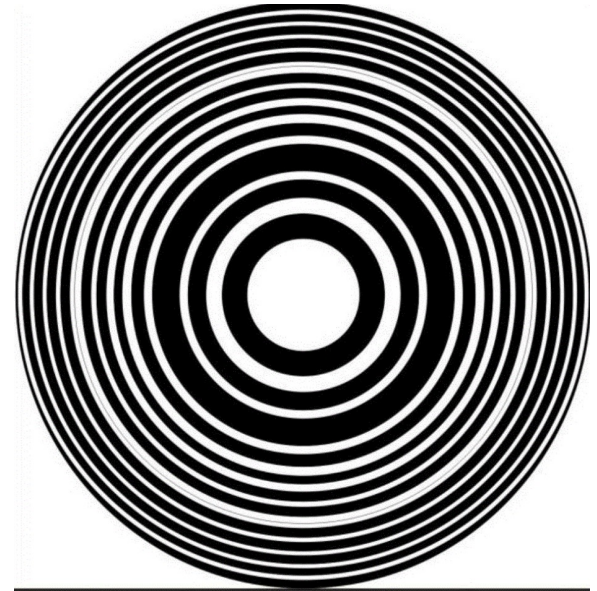

We can use a zone plate to greatly increase the signal photon number.

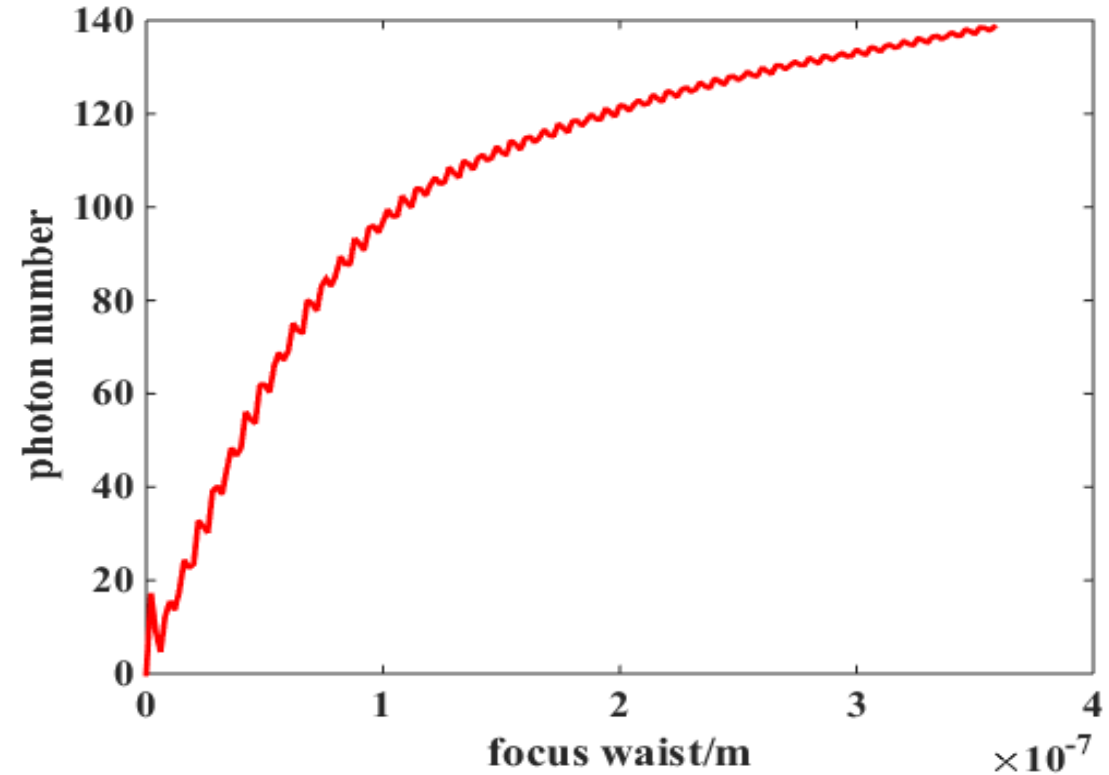
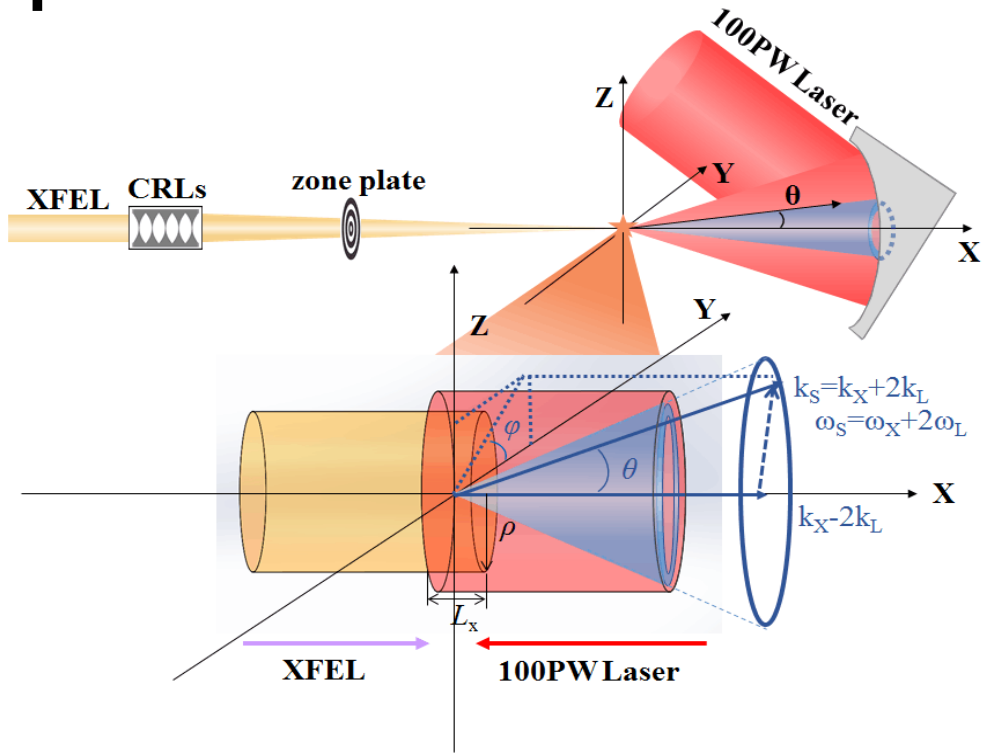

Here we detect signal photon at different place with different photon energy. The high polarization purity is not required.

# Enhancement of vacuum diffraction by interference of signals produced by a probe x-ray free-electron laser with multiple transverse modes

1. Here the focal size of XFEL is larger than that of the optical laser. The XFEL is diffracted by the optical laser. The propagation direction or the transverse momentum is changed.
2. When multiple transverse modes are used, the diffraction could be enhanced in some angle.

TABLE I. The parameters of the pump laser, XFEL, and scattering signal.

	Wavelength (nm)	Photon energy (eV)	Pulse duration (fs)	Focus size ( $\mu\text{m}$ )	Pulse energy (J)
Optical laser	910	1.36	15	5	1500
XFEL	0.096	12914	30		0.002
Signal	0.096	12914	30		

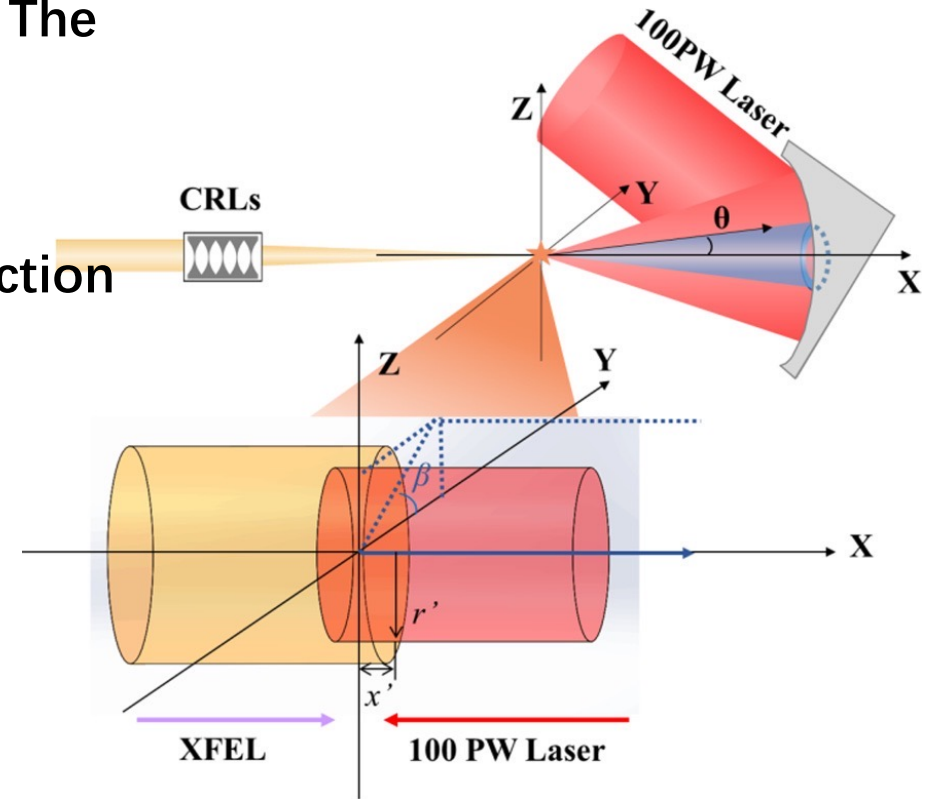

The transverse momentum is changed.

# Enhancement of vacuum diffraction by interference of signals produced by a probe x-ray free-electron laser with multiple transverse modes

The angular distribution of scattering photon for LG (0,0) and LG (0,1) mode is different.

By measuring the angular distribution, we can know the photon-photon scattering.

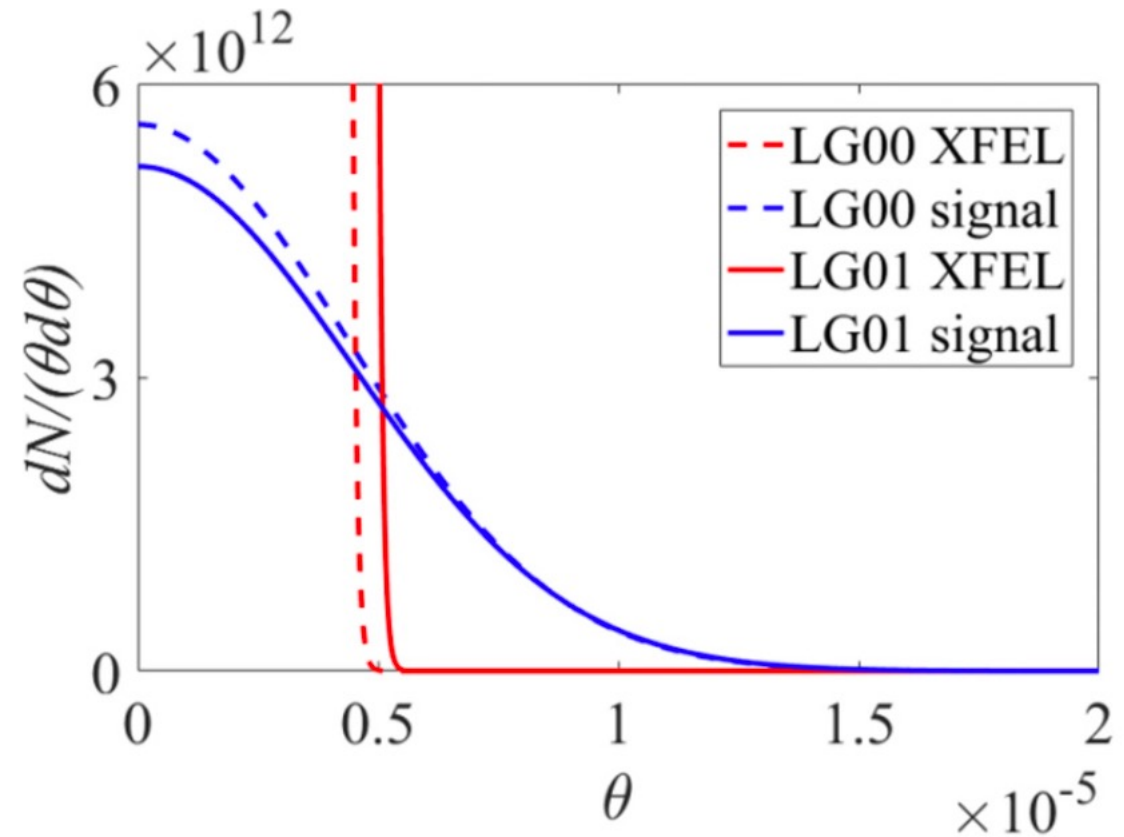

Angular distribution of scattering photon (blue line) and background XFEL (red line) with  $w_x = 25 \mu\text{m}$  and  $w_L = 5 \mu\text{m}$  for LG (0,0) mode (dotted line) and LG (0,1) mode (solid line).

# Enhancement of vacuum diffraction by interference of signals produced by a probe x-ray free-electron laser with multiple transverse modes

$$A_X(r', x', \beta) = \sum_{l,p} \varepsilon_{l,p} \frac{1}{w_X} \left( \frac{\sqrt{2}r'}{w_X} \right)^{|l|} L_p^{|l|} \left( \frac{2r'^2}{w_X^2} \right) \exp\left(-\frac{r'^2}{w_X^2}\right) \exp(il\beta).$$

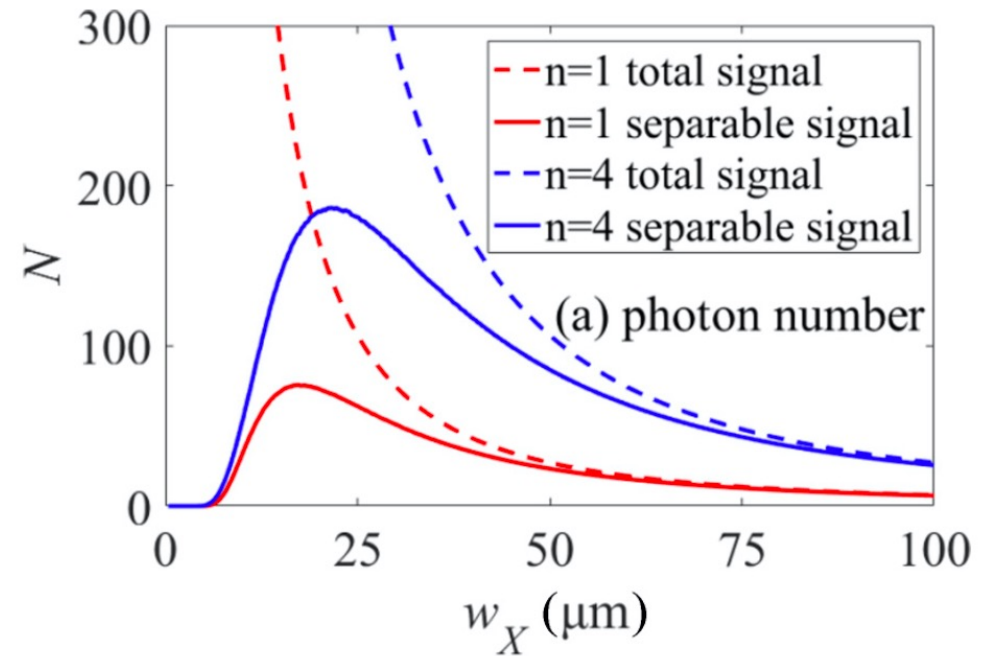
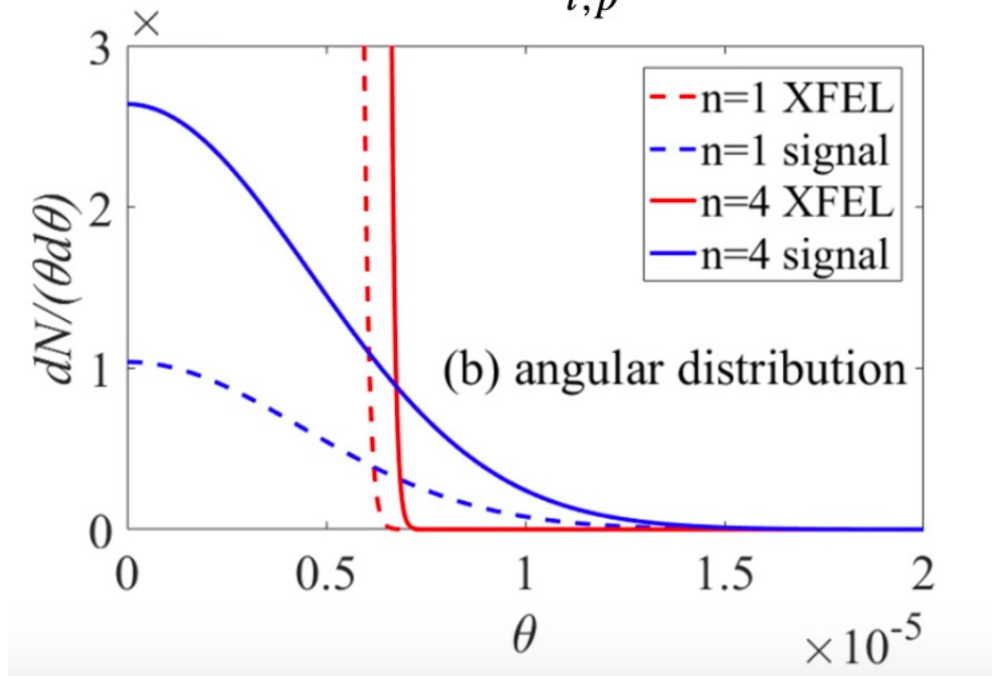

More X-ray photons are scattered to the larger angle due to the interference between the scattering light from different modes.

**Solid lines : detectable photon numbers**



# Outline

1. Background

2. High field Photon-photon scattering

3. High field axion-like particle generation

# Axion-like particle generation in laser-plasma interaction

- In the minimal axion models like the KSVZ model , one axion couples with two photons.
- Viewing from a macroscopic perspective, one can treat this axion-diphoton ('a $\gamma\gamma$ ') process as a three-wave mixing.
- The Lagrangian is

$$\mathcal{L} = -\frac{1}{4}F_{\mu\nu}F^{\mu\nu} + \frac{g}{4}\mathcal{F}_{\mu\nu}F^{\mu\nu}\phi - \frac{1}{2}m_a^2\phi^2 + \frac{1}{2}(\partial_\alpha\phi)(\partial^\alpha\phi)$$

➤  $\phi$  is the potential of the axion-like particle;

➤  $g$  the very weak coupling factor,  $\sim 1.320 \times 10^{-13} \text{ GeV}^{-1}$



## 强场类轴子产生和探测

太阳轴子的探测：

轴子和强磁场相互作用产生光子进行测量

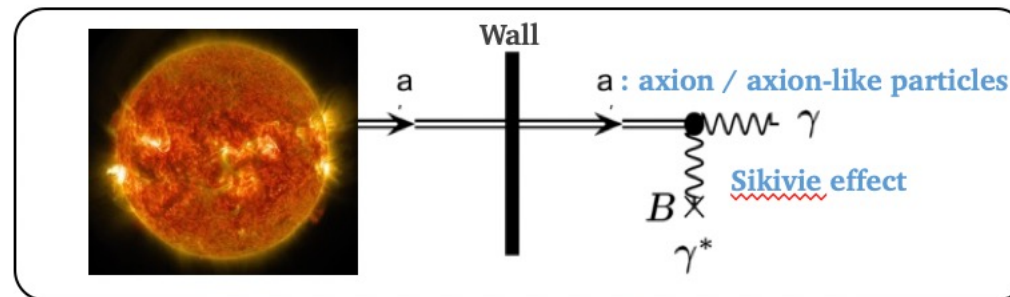

Helioscope, e.g. CAST, (Baby)IAXO

**CAST 的目的是探测能量为 14 keV 的太阳轴子流。若太阳轴子流存在，一个由长数十米的磁铁提供的强度为数十特斯拉的静磁场可以将一部分轴子转换为 X 射线光子，随后被望远镜尽头的 X 射线探测器发现。**

# Summary

PPT由黄杉提供

- LUXE: A groundbreaking experiment for non-perturbative QED
- Data taking is set to start at 2026
- LUXE studies a collision between (in its electron-laser mode)  
16.5 GeV electron and a 40 or 350 TW laser beams



- High-intensity Compton scattering provides a GeV photon flux
  - for BSM physics
  - ... and maybe more
- LUXE-NPOD search can reach the uncharted ALP parameter space for ALP-photon interaction
- ALP/mCP-electron(-photon) studies at the IP

*THANKS FOR YOUR ATTENTION!*

# 强场类轴子产生和探测

LSW方案 = Light Shining through a Wall

- STEP 1: 光在强磁场下产生轴子流。
- STEP 2: 光和轴子流一起运动；光被墙阻挡，而轴子穿墙而过。
- STEP 3: 轴子在强磁场下被转化为光子。

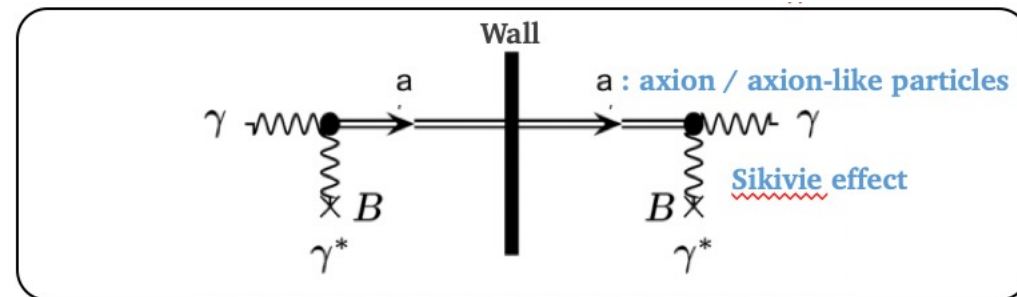
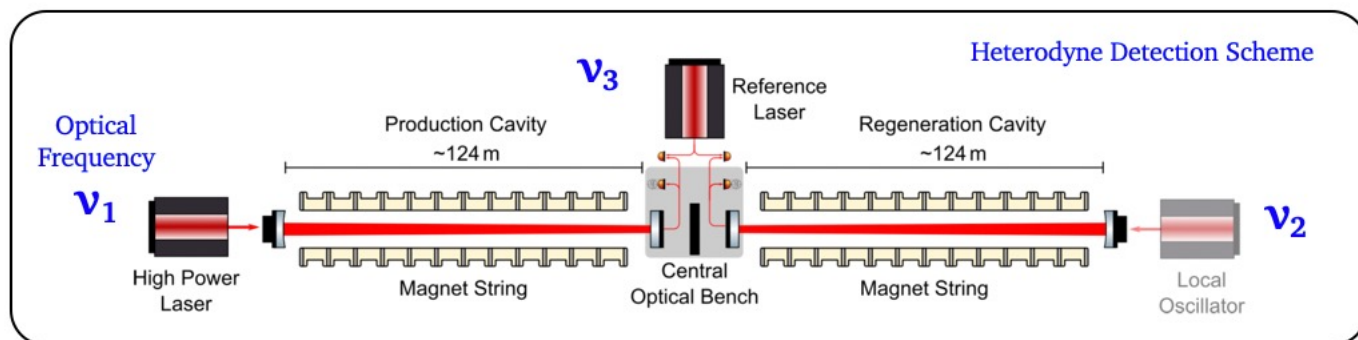

两步过程的信号是二阶小量

# (B) ALPS II Superconducting Magnets

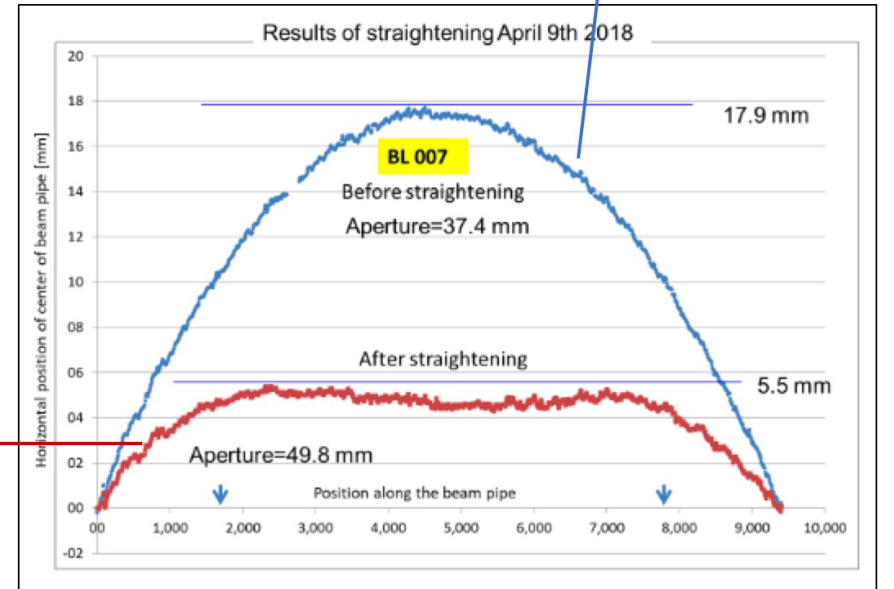
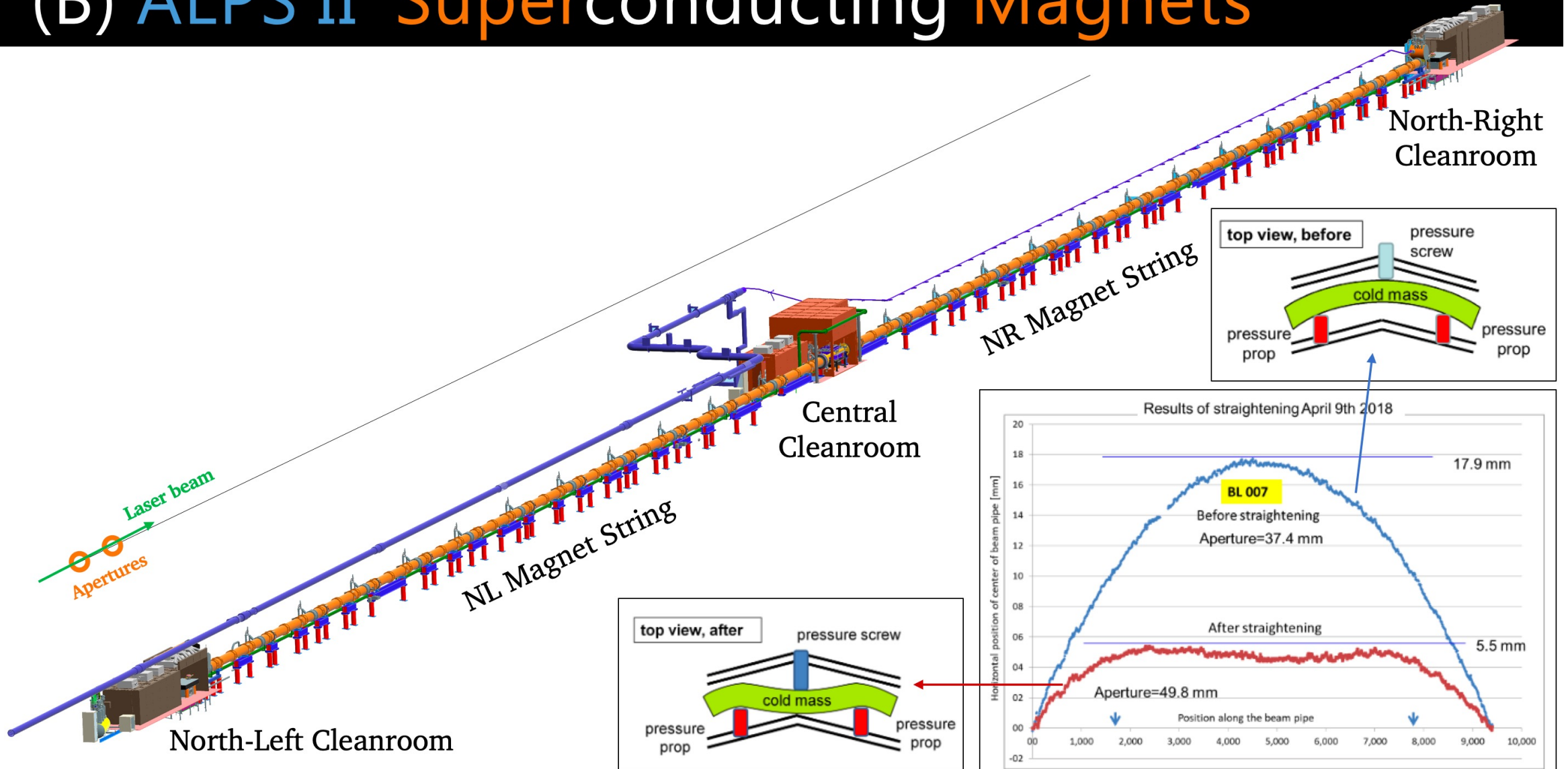

# Axion-like particle generation in laser-plasma interaction

- Electromagnetic interaction may drive the generation of axion-like particle.

$$(\partial_t^2 - \nabla^2 + m^2)\phi = -g\mathbf{E} \cdot \mathbf{B}$$

- At the same time, the production of axion-like particle changes the electromagnetic field.

$$\nabla \cdot \mathbf{E} = g\mathbf{B} \cdot \nabla\phi$$

$$\nabla \times \mathbf{B} - \partial_t \mathbf{E} = g(\mathbf{E} \times \nabla\phi - \mathbf{B}\partial_t\phi)$$

$$\nabla \cdot \mathbf{B} = 0$$

$$\nabla \times \mathbf{E} + \partial_t \mathbf{B} = 0$$

# Axion-like particle generation in laser-plasma interaction

$$(\partial_t^2 - \nabla^2 + m^2)\phi = -g\mathbf{E} \cdot \mathbf{B}$$

- The intense laser provides much stronger electromagnetic field but much smaller interaction area than static magnetic field.
- The laser field of  $a=100$  is 4 orders larger than the static magnetic field of 100T. It means that the interaction length can be reduced from 1km to 10 micrometer.
- One dimensional three wave mixing:

$$\Psi_1 = \psi_1 \exp \{-j(\omega_1 t - k_1 x)\}$$

$$\Psi_2 = \psi_2 \exp \{-j(\omega_2 t \mp k_2 x)\}$$

$$(\partial_{t_2}^2 - \nabla_2^2 + m_{23})\Psi_3 = g_{\text{TWM}}\Psi_1\Psi_2$$

$$\omega_{32} = k_{32} + m_{23}, m_{23} \geq 0.$$

# Axion-like particle generation in laser-plasma interaction

We use the B field the probe and the E field of the laser driven plasma to produce the axion-like particles.

If the polarization direction of probe and the E field direction of the plasma has 45 degree. **The polarization direction of the probe is changed when axion-like particles are produced.**

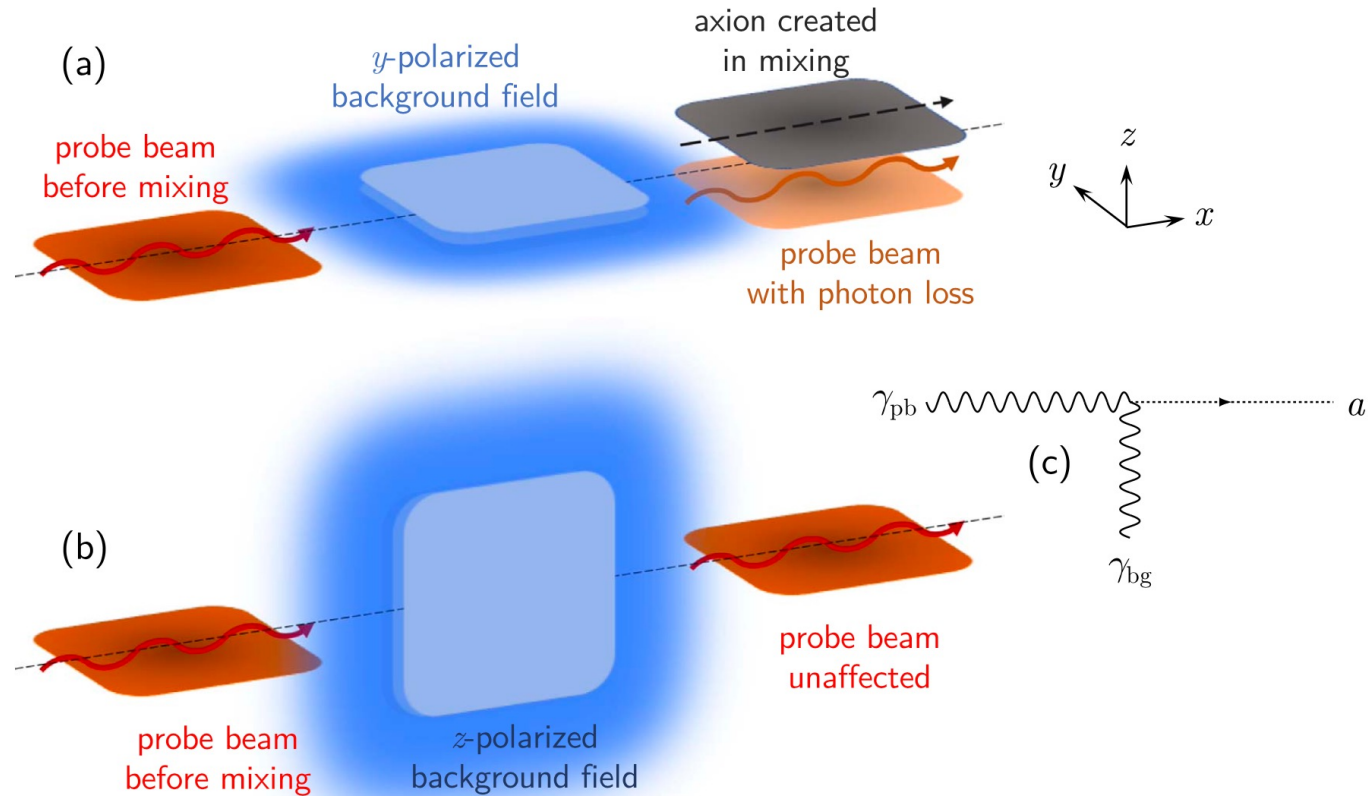

The probe could be XFEL

Sketches of the interaction between a magnetically  $y$ -polarized probe and electrically (a)  $y$ -polarized or (b)  $z$ -polarized background field..



# Axion-like particle generation in laser-plasma interaction

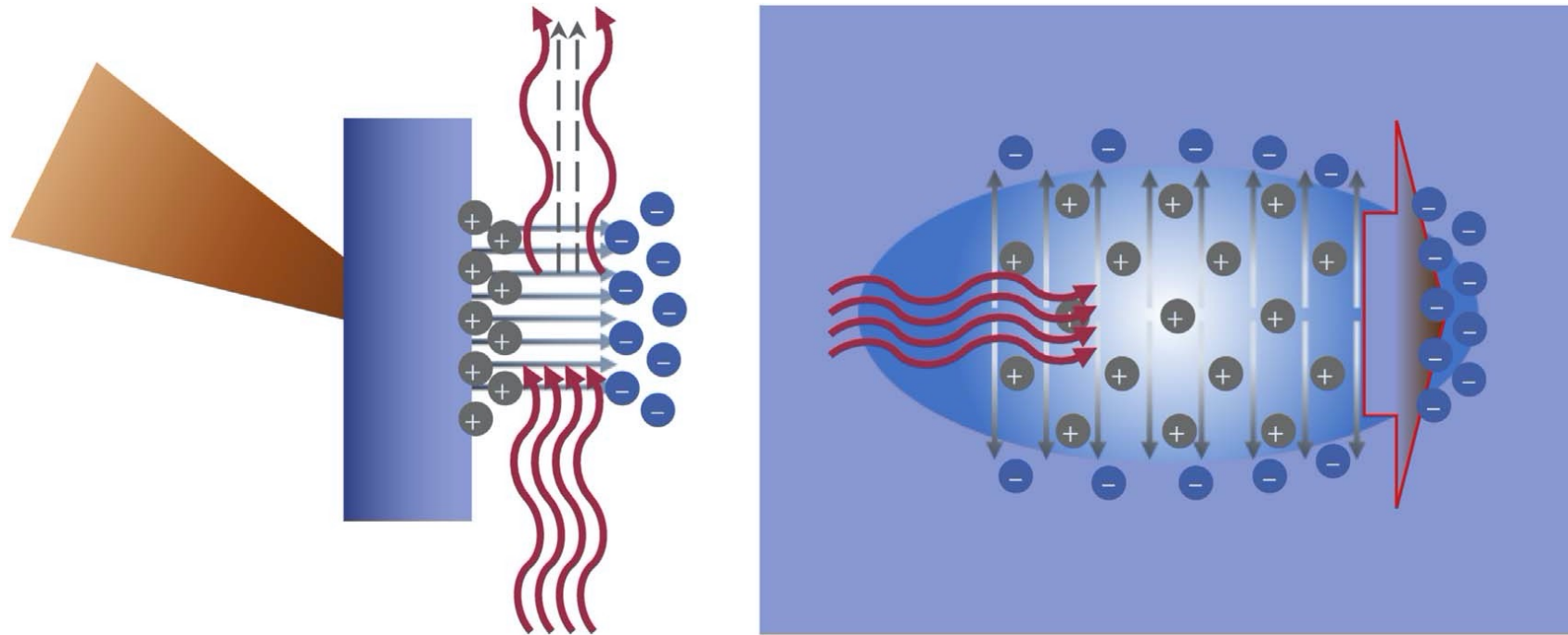

Two cases are discussed.



**Thank you for your attention**

# XFEL driven wakefield acceleration

PHYSICAL REVIEW ACCELERATORS AND BEAMS 19, 101004 (2016)

## Particle-in-cell simulation of x-ray wakefield acceleration and betatron radiation in nanotubes

Xiaomei Zhang,<sup>1,2</sup> Toshiki Tajima,<sup>2</sup> Deano Farinella,<sup>2</sup> Youngmin Shin,<sup>3</sup> Gerard Mourou,<sup>4</sup>  
Jonathan Wheeler,<sup>4</sup> Peter Taborek,<sup>2</sup> Pisin Chen,<sup>5</sup> Franklin Dollar,<sup>2</sup> and Baifei Shen<sup>1</sup>

<sup>1</sup>Shangh

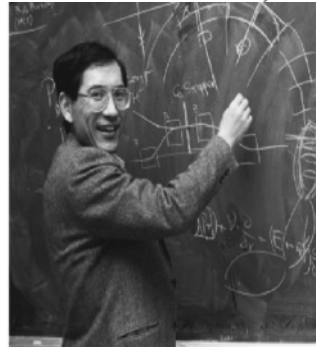

and Fine Mechanics, Chinese Academy of Sciences, Shanghai  
Physics and Astr  
and Fermi Nation  
T, École Polytech  
Leung Center for  
University,  
ived 26 January 2



California 92697, U  
tory, Dekalb, Illin  
u Cedex, France  
le Astrophysics, N  
ober 2016)

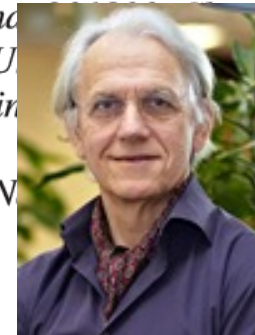

<sup>3</sup>Norther

<sup>5</sup>Depar

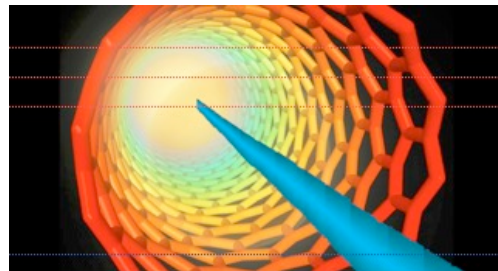

Acceleration gradient can be  
increased greatly by using crystal  
or nano tube.

# Plasma could provide high acceleration gradient

Conventional accelerator  
(gradient =  $10^7\text{-}8\text{V/m}$ )



Radiofrequency cavity (1 m-long)

Laser accelerator  
(gradient =  $10^{11}\text{-}12\text{V/m}$ )

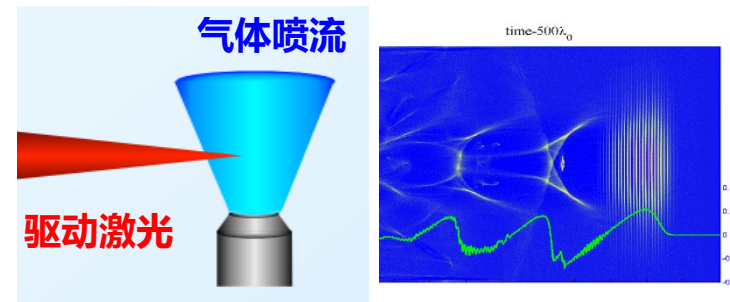

Courtesy of W. Mori & L.O. Silva

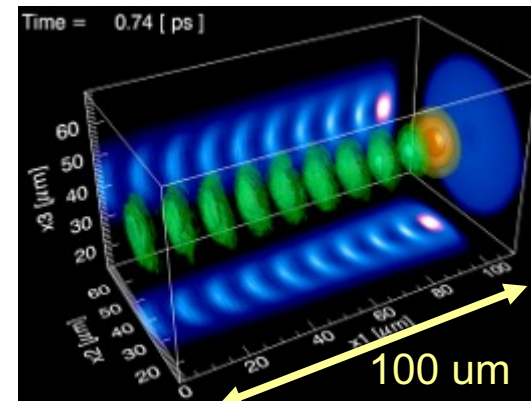

$$E_z = \frac{m_e c v \omega}{p} \approx 300 \text{ GV/m} \quad (\text{for } n_e = 10^{19} \text{ cm}^{-3})$$

3D PIC simulation of a plasma wave (UCLA)

# High-repetition few-attosecond high-quality electron beams generated from crystal driven by intense X-ray laser

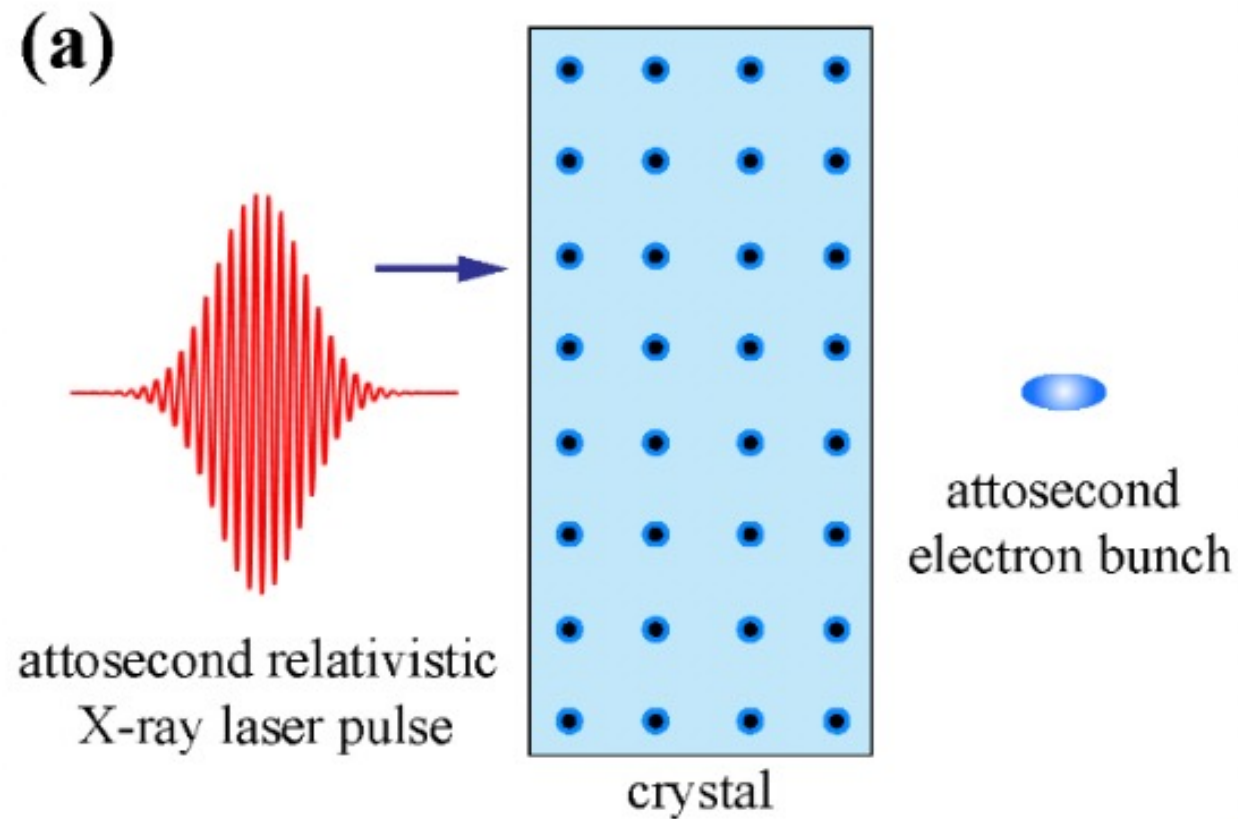



The sharp boundary provides good injection control for electron acceleration.

